

ePassIV

Electronic Deadbolt

Rytan

455 Maple Ave.
Torrance, CA 90503
(800) 447-9826

Fax (310) 212-6002
customer_service@rytan.com

INSTALLATION INSTRUCTIONS

Replacement Installation

1. Remove all old lock components.
2. Use the enclosed template (outside template) to verify the following:
 - A. Deadbolt face hole needs to be 1-3/4 or 2-1/8 (44.5 mm or 54 mm) diameter.
 - B. Backset – Distance from edge of door to center of lock (2-3/8 or 2-3/4).
 - C. Make any necessary modifications.
 - D. Modification will be needed for doors with 1-1/2 diameter face hole. See illustration.

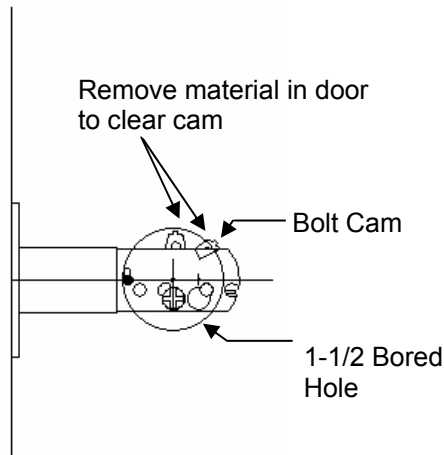

To Adjust Backset

1. Lock is shipped in the 2-3/8" position.
See illustration.

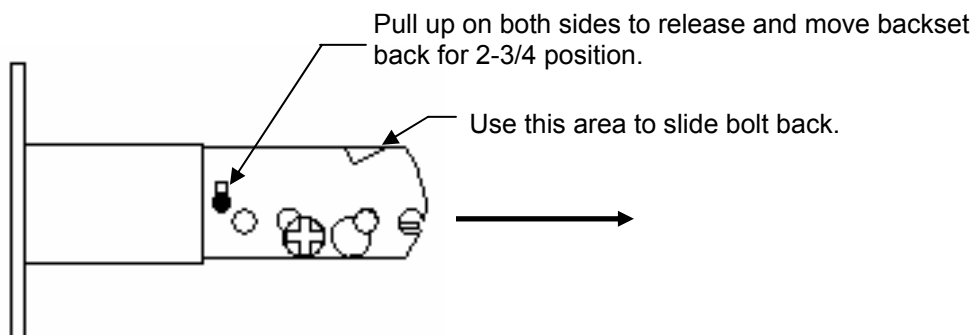

First-time Installation

Rytan

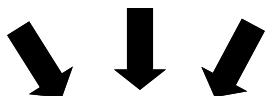

Follow instructions on enclosed "Outside Template".

Face Plate

1. Keeping edges parallel to the door, outline faceplate and remove deadbolt latch (see illustration).
2. Chisel outline of face plate until it is flush with door edge $\frac{3}{32}$ " (3 mm) deep (see illustration).

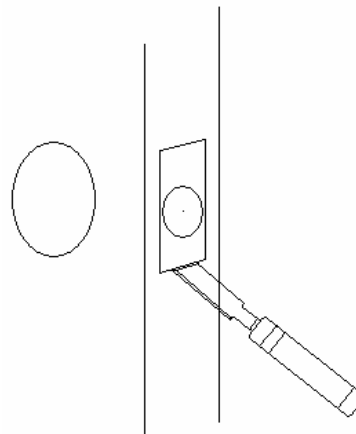
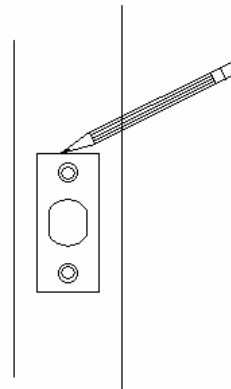

Chisel outline of face
Plate until it is flush
With door edge.

3. Insert deadbolt latch in edge hole. Be sure to keep the hub down.
Secure with two $\frac{3}{4}$ " wood screws.

Strike Box and Plate Installation

First-time Installation

1. For easy location of strike hole, we recommend smearing color (such as grease pencil or crayon) on dimple on the end of the deadbolt latch. Retract bolt and close door. Extend bolt, leaving mark on doorjamb.
2. Pre-drill 2 holes $\frac{15}{16}$ " or 1" diameter centerline-to-centerline $\frac{5}{8}$ " (See illustration) and drill $1\frac{1}{8}$ " (28mm) deep. Chisel out sides so strike box fits and strike plate fits flush. Install strike box and faceplate secure with two $\frac{3}{4}$ " wood screws.

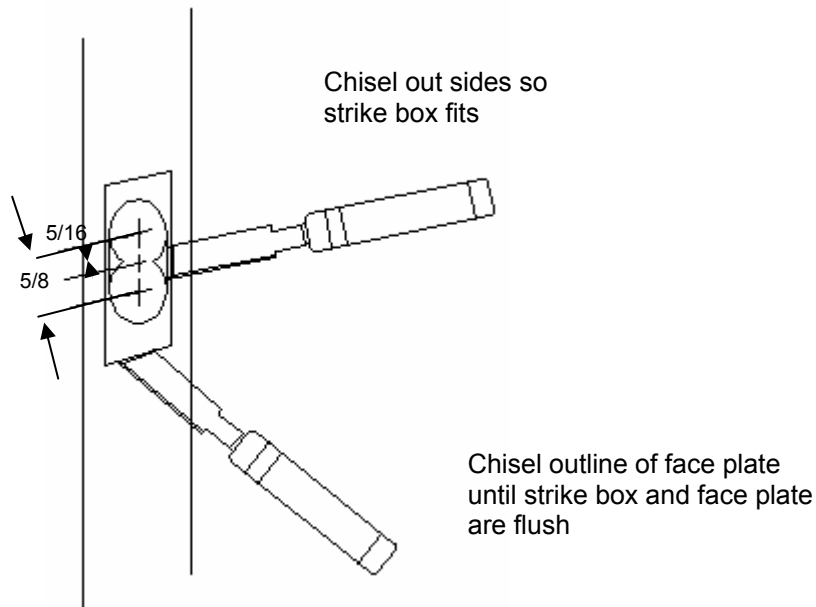

3. Close door and ensure bolt extends and retracts freely.

Important Note.

Dead bolt latch must enter strike with no resistance or the deadbolt will not work properly.

Install ePass IV and T-Turn

1. For right hand door (Note: Deadbolt needs to be in the extended position) have tailpiece on ePass IV in the horizontal position. For the left hand door (Note: Deadbolt needs to be in retracted position) have the tailpiece in the horizontal position.
2. Line up tailpiece with slot in T-TURN.
3. Use the 2 long Phillips screws and attach ePass IV and T-TURN together, but do not tighten only snug unit up. Now check to make sure unit is centered with deadbolt and the ePass IV is vertical. Check that the bolt works smoothly by using the T-TURN.
4. Snug up the 2 Phillips screws (do not over tighten).
5. Install provided 9V- ALKALINE battery. Attach battery-to-battery clip. One beep will sound when battery makes complete contact. Align cap in the little track of the housing and slide cover back on. Be careful not to pinch the battery cable.
6. Check operation of deadbolt first with T-TURN then with the ePass IV (enter code 1,2,3,4,5,6) throw bolt out wait then (enter code 1,2,3,4,5,6) and retract bolt back.
7. Install wood screw in cap to secure cap and ePass IV in the vertical position.
8. Note on batteries: Use only fresh 9V-ALKALINE batteries from brand name manufacturers like DURACELL™.



Customer Information

Rytan, Inc. provides the following information on warranty and service for the ePass IV Electronic Deadbolt:

Shipping and Handling Charges-

- Payment of all shipping and handling charges are the customer's responsibility for all warranty work and for all service work.

Factory Authorization-

- You must contact the factory before sending an ePass IV in for warranty work for all service work.

YOU MAY CALL US TOLL FREE

(800) 447-9826

9:00 AM—4:30 PM Pacific Time

Monday through Friday

Evaluation Fee-

If your ePass IV is found NOT to be defective under warranty you will be charged an evaluation fee which will be applied to parts and labor costs you have authorized, PLUS you will be charged for shipping and handling costs.

If we receive a ePass IV that requires no service you will be charged the evaluation fee PLUS all shipping and handling costs.

The factory will NOT work on any ePass IV where the work has not been authorized by the customer. We must have your authorization before we will begin evaluating your ePass IV and you must be aware of the costs involved before we proceed.

RYTAN RESERVES THE RIGHT TO MAKE CHANGES AT ANY TIME

WARRANTY

(Applicable in the Continental U.S.A. Only)

RYTAN, INC. MODEL ePass IV WARRANTED TO BE FREE FROM MANUFACTURING DEFECTS FOR ONE YEAR FROM THE DATE OF PURCHASE. DURING THE FIRST YEAR DEFECTIVE PARTS WILL BE REPLACED WITHOUT CHARGE FOR PARTS AND LABOR. ePass IV's MUST BE RETURNED TO THE RYTAN, INC. FACTORY FOR ALL WARRANTY WORK. THIS WARRANTY IS NOT APPLICABLE TO ePass IV's WHICH HAVE BEEN ALTERED OR REPAIRED BY UNAUTHORIZED SOURCES OR HAVE BEEN SUBJECT TO NEGLIGENCE, ABUSE, MISUSE, OR ACCIDENT (INCLUDING SHIPPING DAMAGES).

THIS WARRANTY IS EXCLUSIVE AND REPLACES ALL OTHER WARRANTIES, INCLUDING THOSE OF MERCHANTABILITY AND FITNESS FOR A PARTICULAR PURPOSE. RYTAN, INC. WILL NOT BE LIABLE FOR ANY OTHER DAMAGES OR LOSS, INCLUDING INCIDENTAL OR CONSEQUENTIAL DAMAGES FROM WHATEVER CAUSE, INCLUDING BREACH OF WARRANTY OR NEGLIGENCE.