

# RY100/RY200

**Rytan**  
INCORPORATED

## CUTTER REPLACEMENT

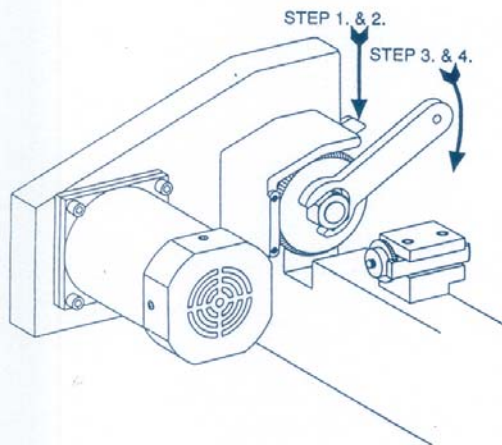

### RY100 CUTTER REPLACEMENT

1. Press and hold Down the Cutter Shaft Locking Lever as illustrated to the left.
2. Turn the Cutter Nut until the Cutter Shaft Locking Lever drops into the Cutter Shaft Assembly and stops the cutter from turning. KEEP PRESSING DOWN ON THE CUTTER SHAFT LOCKING LEVER.
3. Use a 1" wrench as illustrated to loosen the Cutter Nut.
4. Operate the wrench as illustrated by PRESSING DOWN.

REMEMBER--YOU ARE REMOVING A LEFT-HAND THREADED NUT (turn right to loosen/turn left to tighten).

Sometimes a Cutter Nut is turned the wrong way in attempting to remove it. In situations like this the cutter nut becomes so tight that the Cutter Shaft Locking Lever strips the locking notch in the large pulley and the cutter nut can not be removed using the cutter shaft locking lever.

Use the following procedure to remedy this situation.

Use a fresh 1/4" diameter drill bit with your electric drill as illustrated. Secure the drill bit with 1-1/4" sticking out from the electric drill chuck. Use a felt tip pen to mark the drill bit shank at 1-1/4" from the tip of the drill bit if necessary. Cut out the Template to the right by cutting along the dashed lines. Cut out the center as instructed on the Template.

Remove the Key Machine Belt Guard as illustrated to expose the Cutter Shaft Pulley.

Position the cut-out Template over the center hub of the large pulley and drill the hole with your electric drill as illustrated. Remember to position the Template with the word "TOP" at the top of the key machine pulley.

Drill the 1/4" diameter as instructed on the Template. When you are finished you should blow out any loose chips created during the drilling operation.

Place a 1/4" shank diameter Phillips screwdriver into the hole in the pulley and into the machine housing and remove the cutter Nut using your 1" wrench as illustrated at the top of these instructions.

